

**novatexx**



pure

**Nonwovens for filtration membranes and  
filter cartridges**

**viledon®**



## novatexx: making sure that membranes keep their promises

With its Viledon novatexx product line, Freudenberg offers top-quality nonwovens for manufacturing filtration membranes and membrane cartridges for various filtration and separation jobs.

Processes include micro-, ultra- and nano-filtration and reverse osmosis. Membrane filter systems are used in the food and beverage industries, in drinking-water or sewage treatment, in the bio-pharmaceutical sector, semiconductor production or in technical medical products.

Polymer-based membranes usually require additional mechanical reinforcement. This is essential to withstand the physical stresses involved in production, further processing and actual use. Freudenberg provides a wide spectrum of first-class nonwovens, which for many years have given excellent service as carrier and drainage media.



## Always the right choice

Thanks to a multiplicity of production technologies, Freudenberg offers specifically tailored solutions for filtration jobs:

- **spunbonded nonwovens**
- **JetSpin nonwovens**
- **dry-laid nonwovens**
- **wet-laid nonwovens**

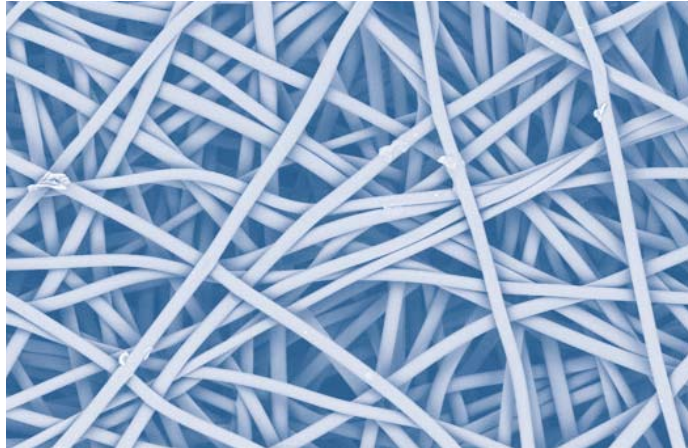

*SEM picture of a high-performance filter medium*

Together with the basic processes involved, the different bonding and finishing processes and fiber mixtures combine to create an extensive product range featuring specific properties in regard to:

- **collection rate**
- **long useful lifetimes**
- **mechanical strength**
- **rigidity**
- **resistance to chemicals**
- **thermal stability**

Thanks to intensive research work, Freudenberg repeatedly develops innovative products and continual optimization of all its services. One example of our current innovations is new polyester nonwovens with an asymmetrical structure for fine filtration. The promising thrusts in our research work include nanofibers and functionalized nonwovens.



You will find further product information on nonwovens for liquid filtration on our website at

[www.viledon-filter.com](http://www.viledon-filter.com)

## A perfect combination

Flat membranes, e.g. for micro-filtration, ultra-filtration or reverse osmosis, are found in different filter shapes: in spiral windings, plate or cassette modules, and in punched blanks. Usually, the membranes are so thin and fragile that they can only be produced by direct coating of a carrier material's surface. This substrate provides the membrane with the requisite mechanical strength needed to withstand the production process all the way through to the final application.

In order to produce flawless, high-performance membranes, carrier nonwovens have to exhibit a high degree of uniformity in terms of thickness, porosity and surface properties. Moreover, very good fiber bonding is essential in order to reduce membrane defects.

novatexx nonwovens are manufactured from either polyester or polypropylene/-polyethylene polymer materials, providing membranes with the requisite stability. The choice of the right material is governed by the chemical and physical conditions of the application concerned and by statutory guidelines. In order to optimize the carrier fleece in terms of strength, uniformity or membrane adhesion, Freudenberg uses a variety of production processes, like dry-laid or wet-laid technology.

The novatexx range also includes very thin nonwovens, which are an integral constituent of the production process for micro-filtration membranes.

Some nonwovens are made up of bicomponent fibers, and are also suitable for lamination with unreinforced membranes. These can thus be reinforced retrospectively, customizing them for the specific requirements involved.



Flat membrane

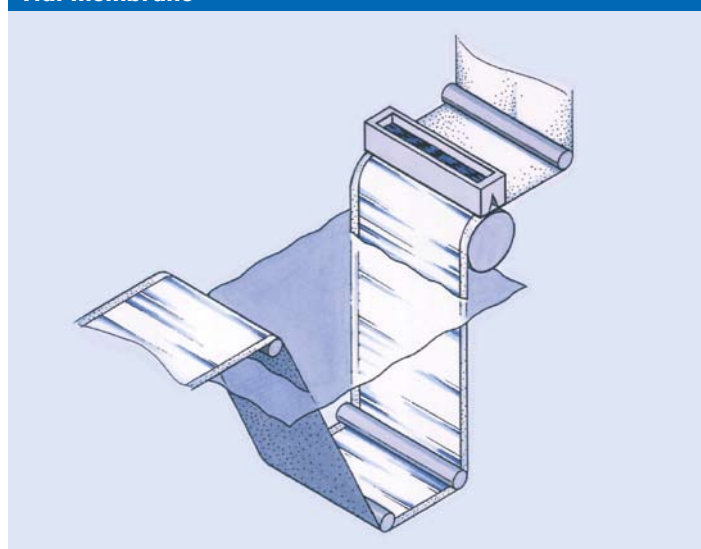

### Typical products for flat membranes:

- polypropylene/polyethylene nonwovens, 30 - 100 g/m<sup>2</sup>
- polyester nonwovens, 70 - 130 g/m<sup>2</sup>

## Double impact

In the continuous production process for tubular membranes, a narrow strip of the carrier material (nonwoven) is wound to form a tube, welded using ultrasonics, and coated with the membrane solution. This process and the application conditions (particularly maximum operating pressure and temperature) require nonwovens with high longitudinal and transverse strength, rigidity and good weldability; good weldability requires appropriately uniform density and thickness.

The novatexx range of tubular membranes includes polyester and polyolefine nonwovens with different weights per unit area and surface structures, suitable for performing strength-enhancing or membrane carrier functions. These nonwovens are supplemented by a variant with imprinted polyethylene adhesion points, which in the lamination process with another membrane carrier serve as a hotmelt adhesive.

### Tubular membrane

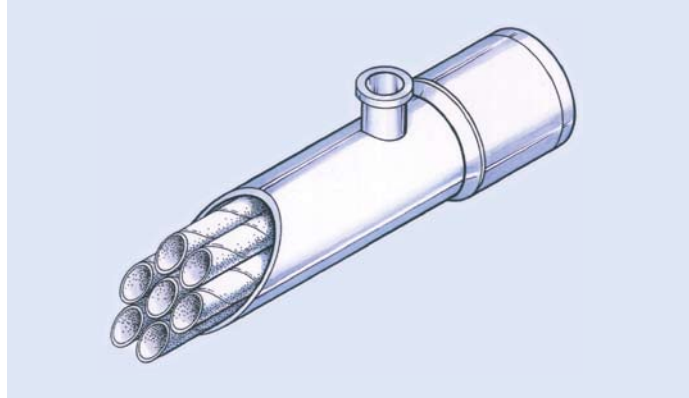

#### Typical products for tubular membranes:

- calandered polyester nonwovens, 100 – 230 g/m<sup>2</sup>
- polyester nonwoven with adhesion points, 250 g/m<sup>2</sup>
- polypropylene/polyethylene nonwovens, 200 g/m<sup>2</sup>

## Every pleat counts

Filter cartridges with pleated membranes will deliver their full performance only if the filter's entire surface area can actually be used. novatexx spunbonded nonwovens enable this: as "spacers" between the pleats on the face side and as a drain-

age layer on the clean side. The media's performance profile can be very specifically modified – e.g. in terms of weight per unit area, thickness or permeability. Moreover, the nonwovens can be easily pleated with the membrane without damaging it, and then converted into filters. Freudenberg uses only top-quality raw materials. That's why novatexx filter media meet the regulations for safety in the food, medical and pharmaceutical sectors.

Besides the field-proven polypropylene spunbonded nonwovens, the novatexx portfolio also includes other polymers: like polyester nonwovens, which are suitable for specific chemical-physical process conditions.

#### Typical products for filter cartridges:

- polypropylene spunbonded nonwovens, 20 – 50 g/m<sup>2</sup>
- polyester spunbonded nonwovens, 30 – 70 g/m<sup>2</sup>

### Pleated filter cartridge

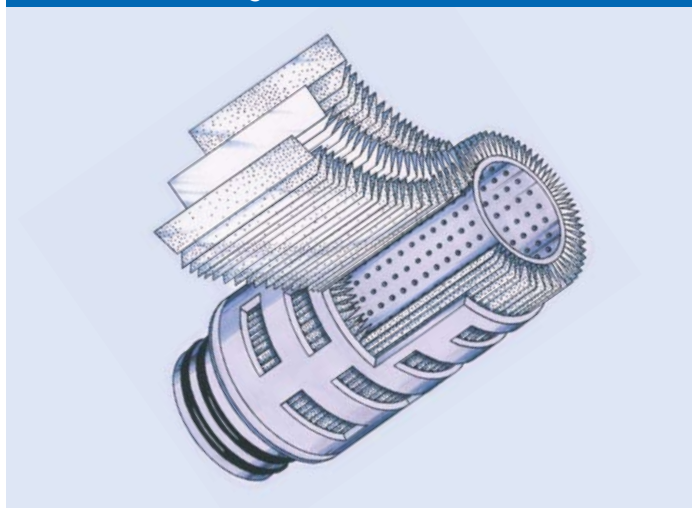

## Sales companies

### France

Freudenberg Filtration Technologies SAS  
viledon-fr@freudenberg-filter.com  
www.viledon-filter.com

### Germany + Scandinavia

Freudenberg Filtration Technologies KG  
viledon@freudenberg-filter.com  
www.viledon-filter.com

### Italy

Freudenberg S.p.A. a socio unico  
Divisione Filtrazione  
filter.MI1@freudenberg-nw.com  
www.viledon-filter.com

### Poland

Freudenberg Vlene Sp. z.o.o.  
Filtration Technologies Division  
vlene@freudenberg.pl  
www.viledon-filter.com

### Spain

Freudenberg España S.A.  
Telas sin Tejer, Sociedad en Comandita  
División Filtración  
jordi.borras@freudenberg-nw.com  
www.viledon-filter.com

### United Kingdom

Freudenberg Nonwovens L.P.  
Viledon Filtration  
viledon.filtration@freudenberg-filter.com  
www.viledon-filter.co.uk

### USA

Freudenberg Filtration Technologies L.P.  
Liquid@freudenberg-filter.com  
www.viledon-filter.com

## Freudenberg Filtration Technologies KG

69465 Weinheim / Germany  
Telefon +49 (0) 6201 80-6245 | Fax +49 (0) 6201 88-6685  
viledon@freudenberg-filter.com | www.viledon-filter.com

